

TIM **METAL** **W** S A L E S

9929 E US HWY 50 Cannelburg, IN 47519
812.486.4299 - 812.486.4344 (fax)

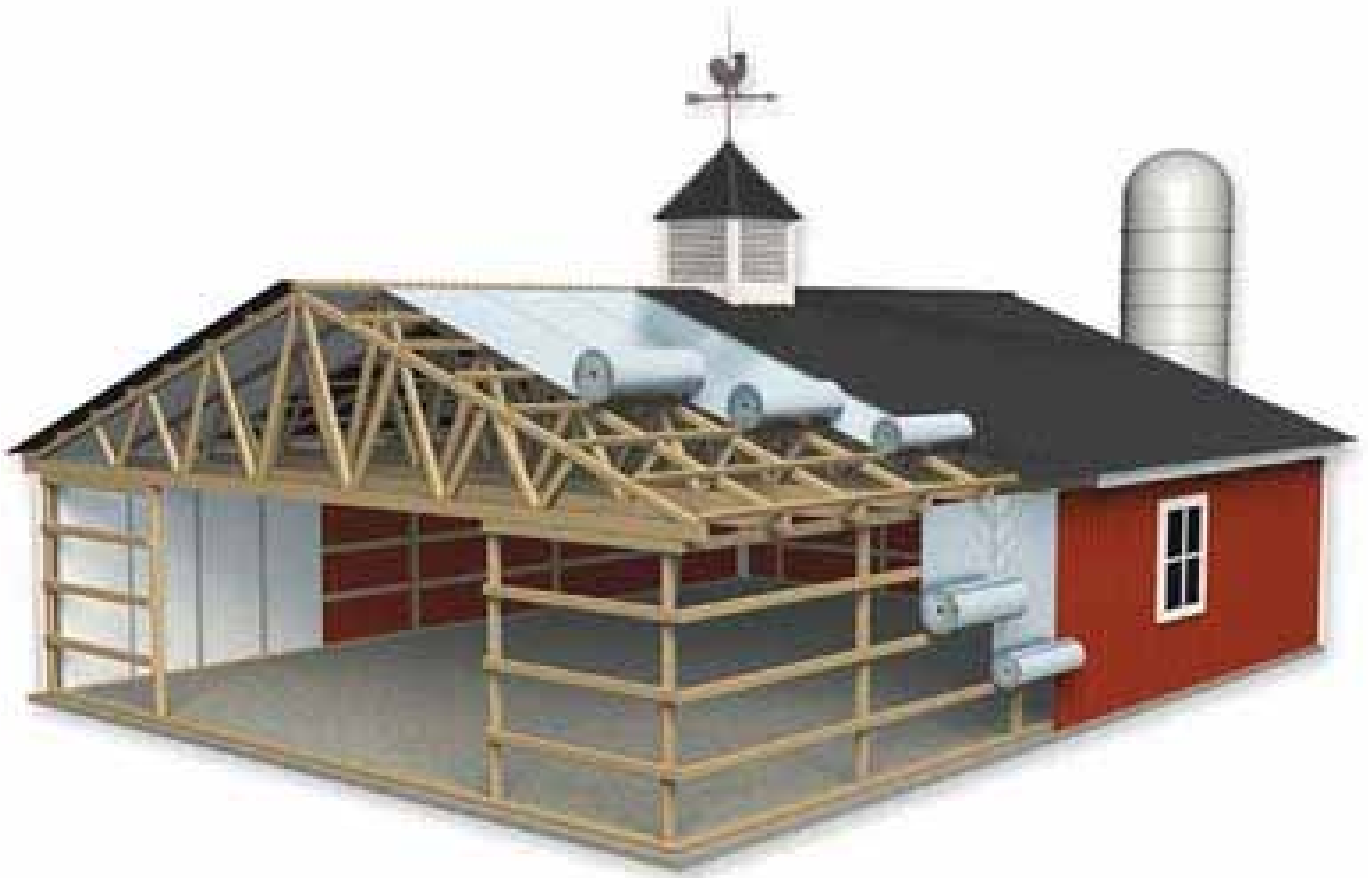

GENERAL POST BUILDING CONSTRUCTION PROCEDURES

A post building can be constructed several ways. One set of steps is listed below. The success of any building project depends upon prior planning, effecient use of labor and machinery, convenient location of materials and components, good drainage and weather.

Layout and Excavation

1. Select the site.
2. Remove sod, fill, compact and grade with bulldozer or tractor scoop. The amount of site preparation depends on the use of the building. Little site preparation may be needed for a storage structure except to keep runoff water away. In contrast, the site for a livestock barn with concrete floors requires good drainage and a good base for a concrete floor.

3. Lay out building with stakes and sting lines. The building line is normally at the edge of the wall girts. Drive a stake at one corner. Line up and set four stakes several feet of each corner and stretch a string along each side and end. The distance between both diagonal corneres should be within 1" of being the same to assure a square building.

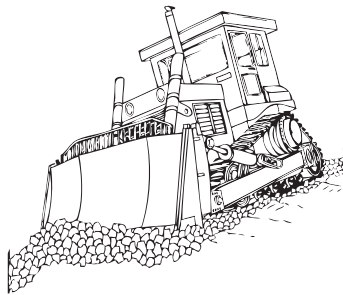
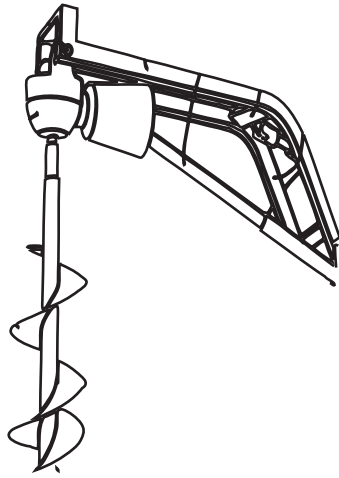

4. Mark post locations with ground limestone or small stake. Remove stretched string lines.
5. Bore Holes with truck or tractor-powered 10"-16" diameter auger 3'-6' deep, depending on frost depth. Dig holes wide and deep enough to install casing or at least 8" larger than the post.

Placing Concrete

6. Remove water or loose material from bottom of holes.
7. Place 1/2 of 80 lb bag of dry concrete in hole.

Setting Posts

8. Select 4 straight corner posts.
9. Place posts in holes. Raise posts with a tractor hydraulic loader and timber hitch or nonslip attached above the mid-height of the pole. sling toward inside of building.

10. Replace string lines and plumb the two outside edges of corner posts with a carpenter's level and straight edge. Keep post at preset distance from string lines, usually the width of the girt or 1 1/2".

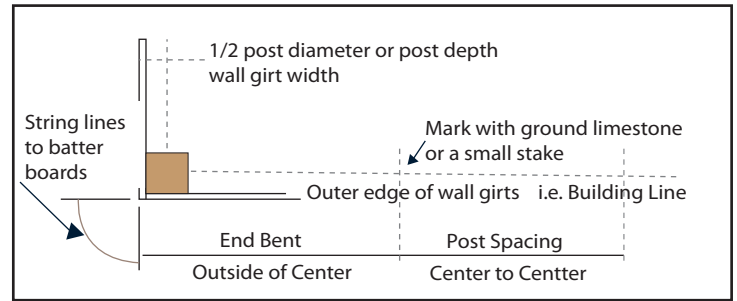

Figure 6. Location posts and string lines (Step 10)

11. Drive 2x4 stakes within building lines. Brace posts with 2x4's (Fig. 7).

12. Locate, center and plumb outside edge of all posts. Brace with 2x4 to driven stakes and to adjacent posts. Be sure to place braces so they will not interfere with the truss installation. Put balance of dry concrete in hole. fill holes and tamp to one-third depth only. (Fig 7.)

Note: End bay or section is often shorter than interior bays because dimension may be from outside of end wall girts to center of second post.

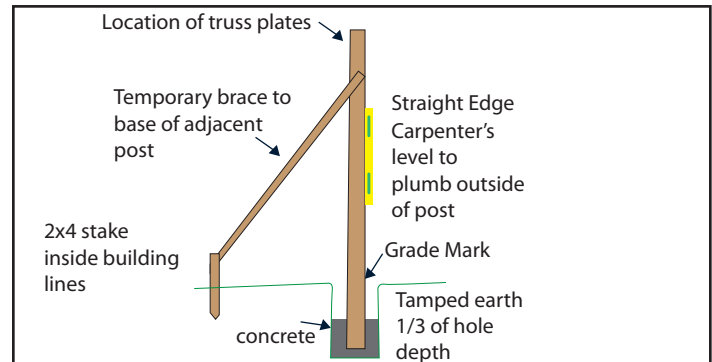
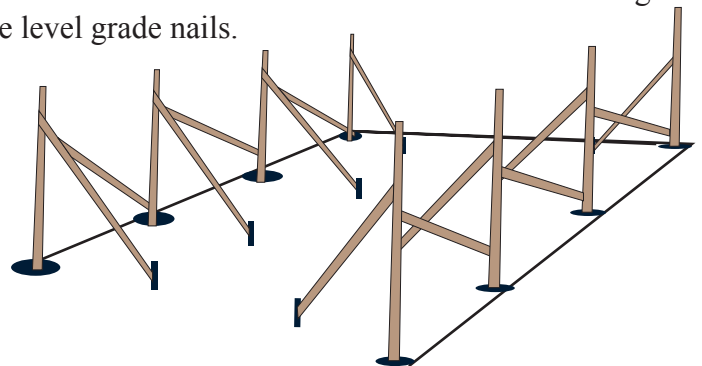

Figure 7. Alignment and temporary bracing of posts (Steps 11 and 12)

13. Mark grade level with nail driven partly into outer edge of each post. take a transit or level, and make a level mark on all of the posts.

Installing Truss Plates

14. Measure and mark with a partly driven nail in the desired height to the bottom of the truss plate. Cut a straight board or 2x4 to this dimension for fast and consistant marking from the level grade nails.



15. Cut truss plates square and to exact length. Truss plates should butt at center line of posts except at corners. Check corner details on plans for lengths and nailing.
16. Building double truss plate with tie-down blocking at correct truss spacing. Start 3-4-5" pole barn nails near each end of truss plate.

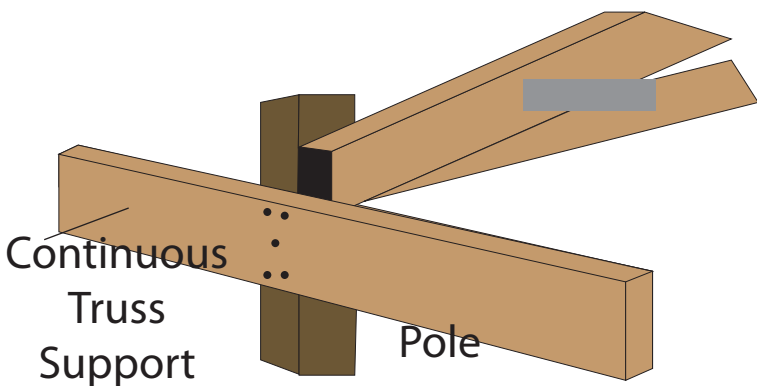

Figure 8. Built-up Truss Plate with tie down blocks. Truss plates can be built on the ground and installed as a unit or assembled in place. (Steps 16 & 17)

Place double truss plate on posts and nail with the end at the post centerline. Use a truck bed or moving scaffold instead of ladders.

Alternate Truss Plate Installation Method

- 16a. Place truss plate on post. Nail with three 4-5" pole barn nails. Use a truck bed or moving scaffold instead of ladders.
- 17a. Cut and install truss tie-down blocks at correct spacing as called for in plan.

Bracing and Alignment

18. Install truss plate to post bracing and complete truss nailing.
19. Check alignment of posts and trusses. Move temporary braces if realignment or lateral support is needed.
20. Remove string line. Fill and tamp all holes.

Roof Framing and Bracing

21. Check trussed for correct width (outside to outside of truss plates).
22. Place trussed on truss plates next to the tie down blocking. Trusses may be placed with crane. Tractor front-end loaders with an extended boom can lift light trusses, etc. Be careful, front-end loaders can tip with heavy loads.
23. Check correct width and fasten to pole and tie the bracing.
24. Fasten several roof purlins (extended for end gable overhangs) using spacers to check truss spacing. roof purlins are usually butted, especially with even truss spacings. At ridge, space for ridge roll or for open ventilation.
25. Nail wind bracing at least every 20' of building length. Manufactures recommendations.
26. Nail bottom chord stiffeners in place if trusses are used.

Roofing

27. Install roofing starting at lower corners so side laps are away from the strongest winds. Use nails that do not corrode the roofing. Nail/Screw through the top of the ribs into purlins.

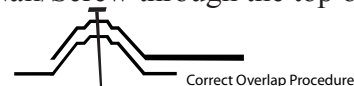

28. Measure between edge of roofing and end of roof every 30' to be sure roofing is square.

Siding and Finishing

29. Remove temporary post bracing. Use for wall girts
30. Install knee bracing
31. Install side and end wall girts
32. Install plank skirts, windows(if desired), siding, doors.
33. Install trim, eave troughs, etc.

This brochure is provided for illustration purposes only. Assistance from consultants, inspectors, or specialists may also be considered. Check local building codes for the requirements in your area.

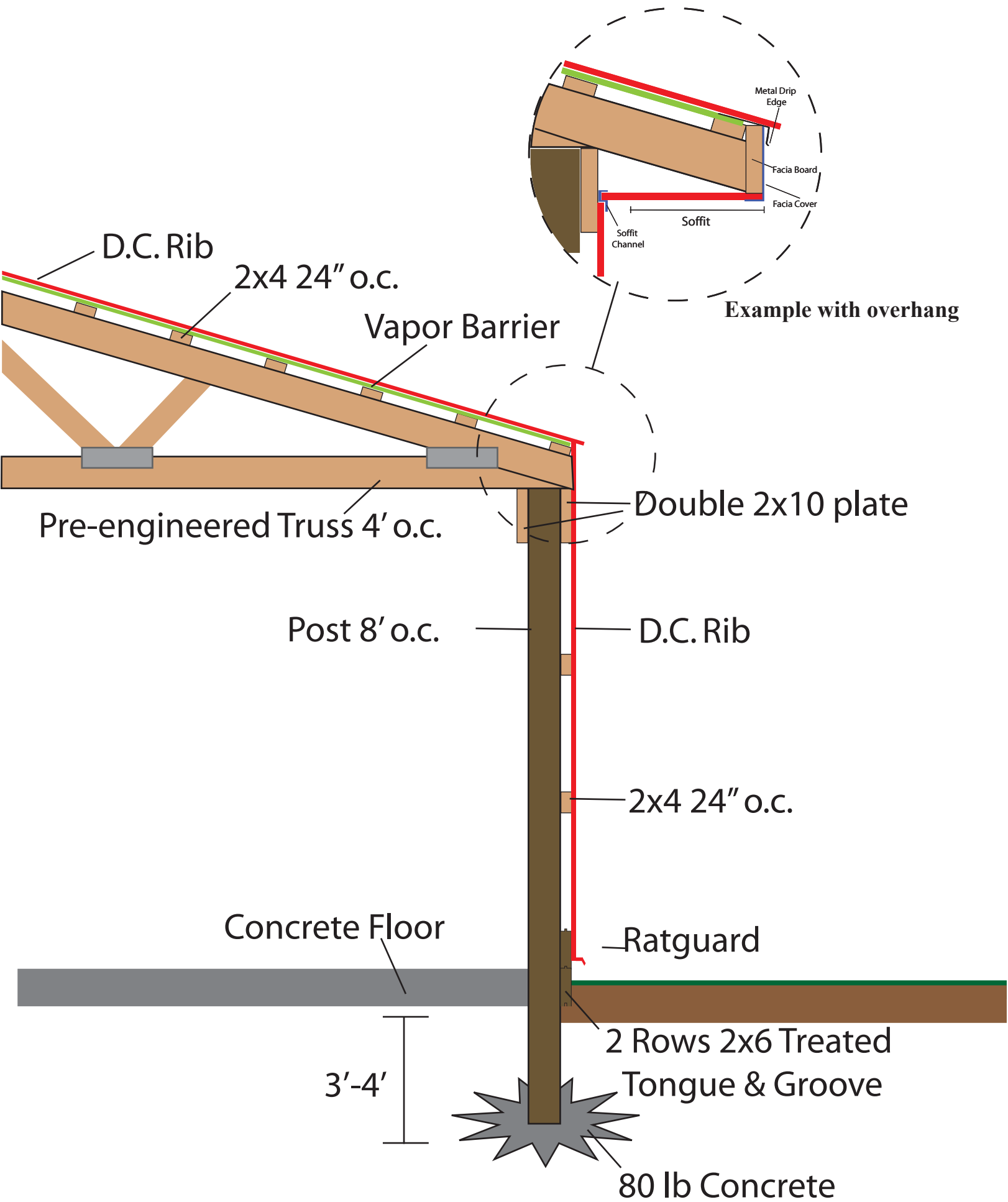

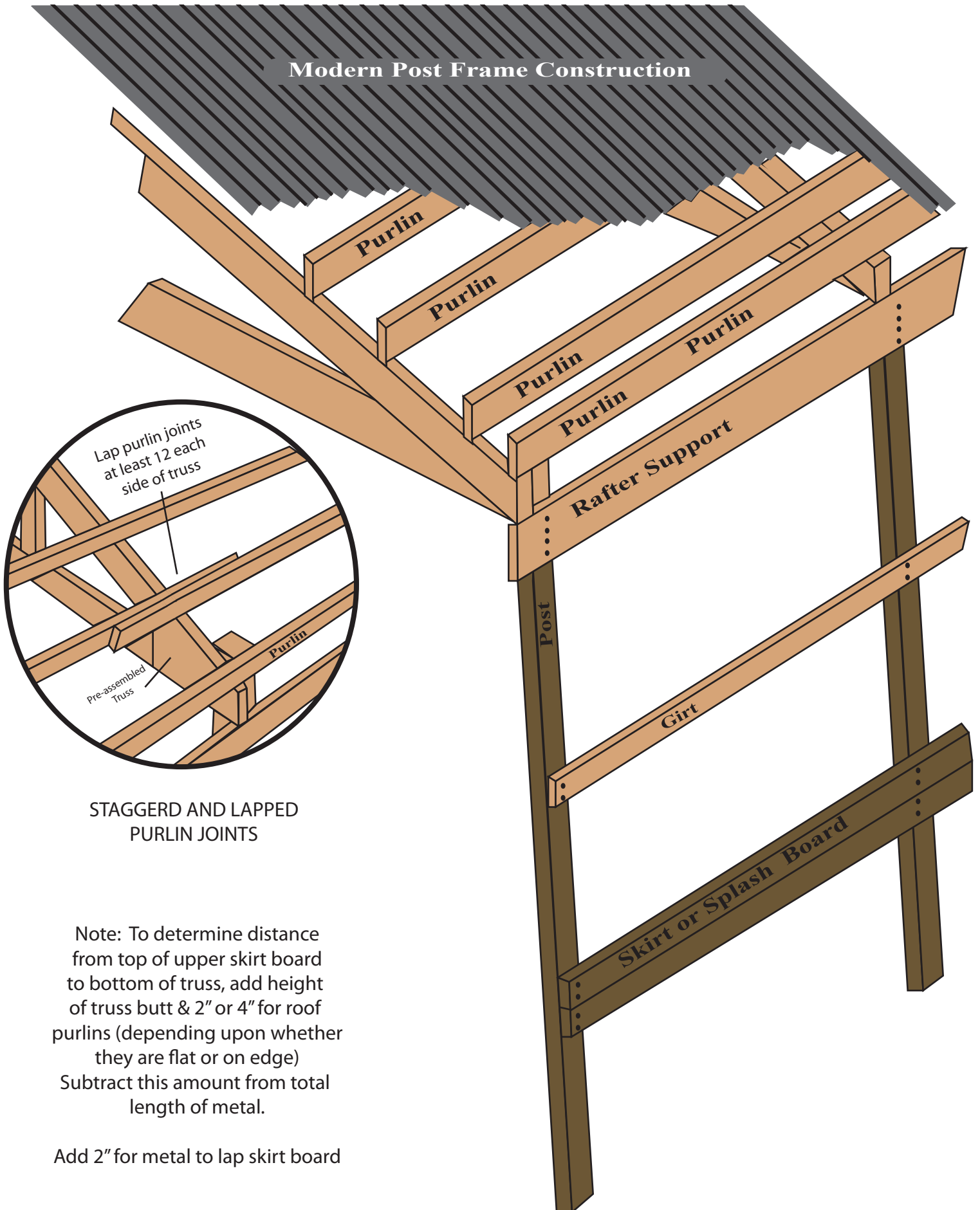

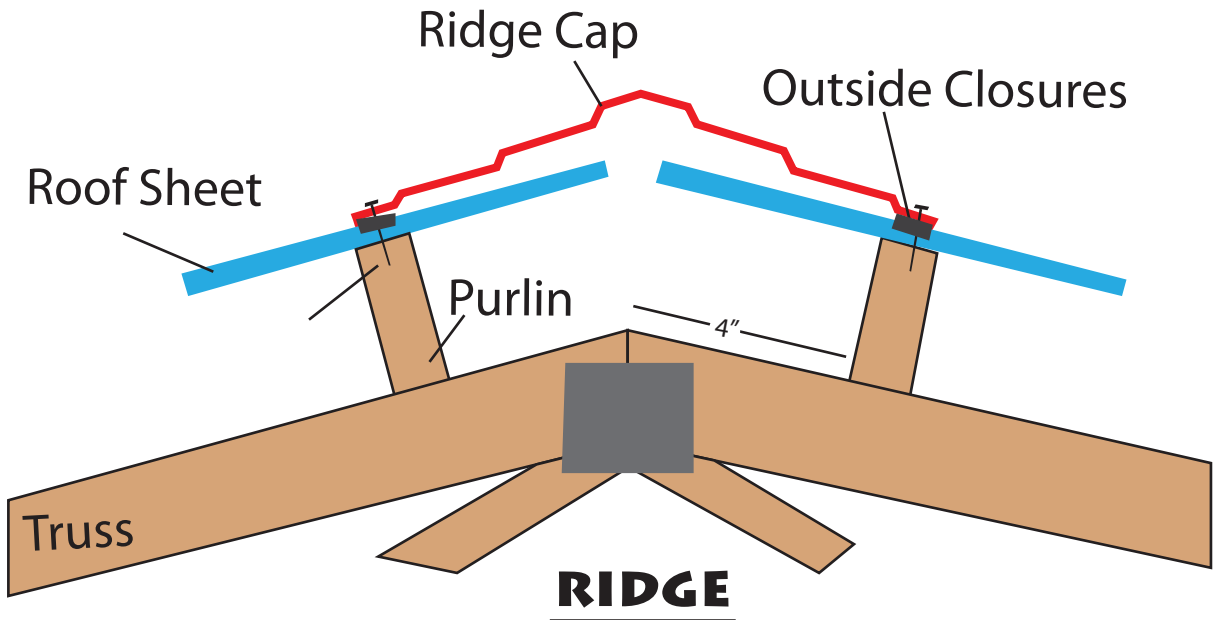

RATGUARD

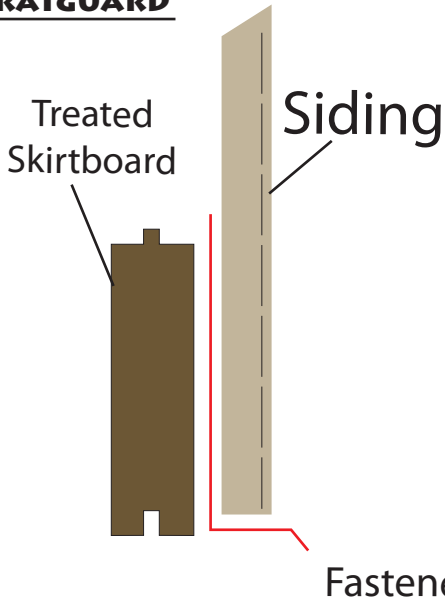

OUTSIDE CORNER

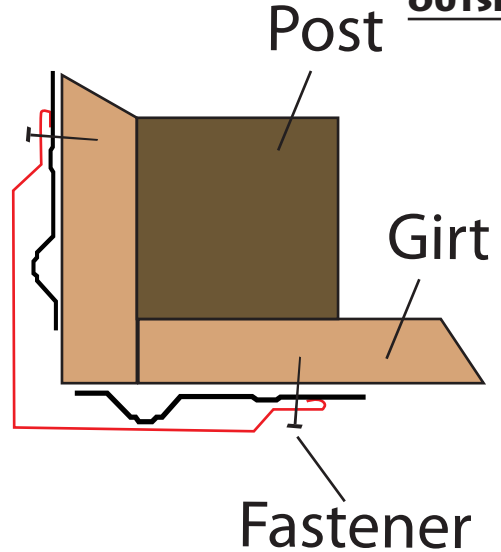

GABLE

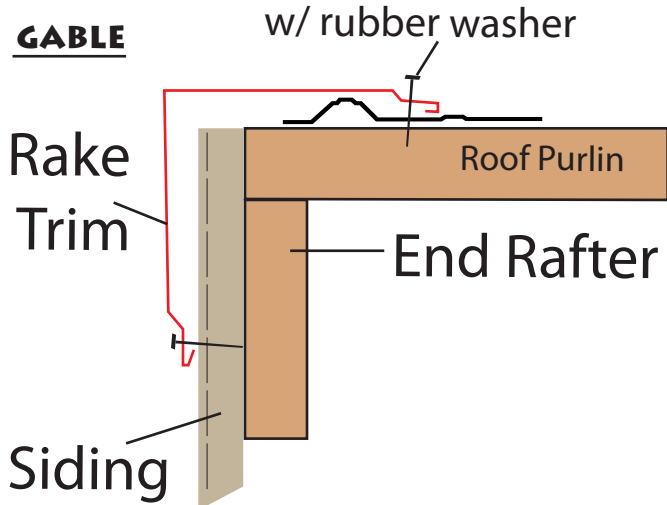

OVERHEAD DOOR JAMB

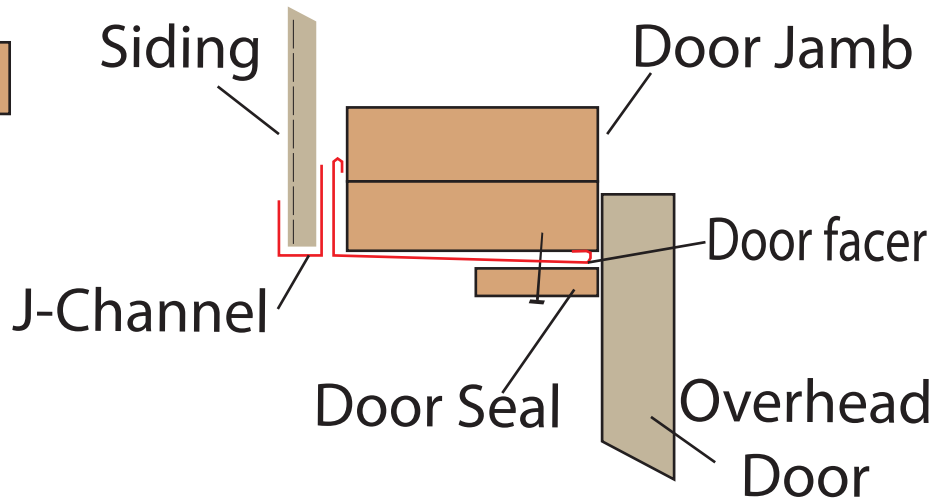

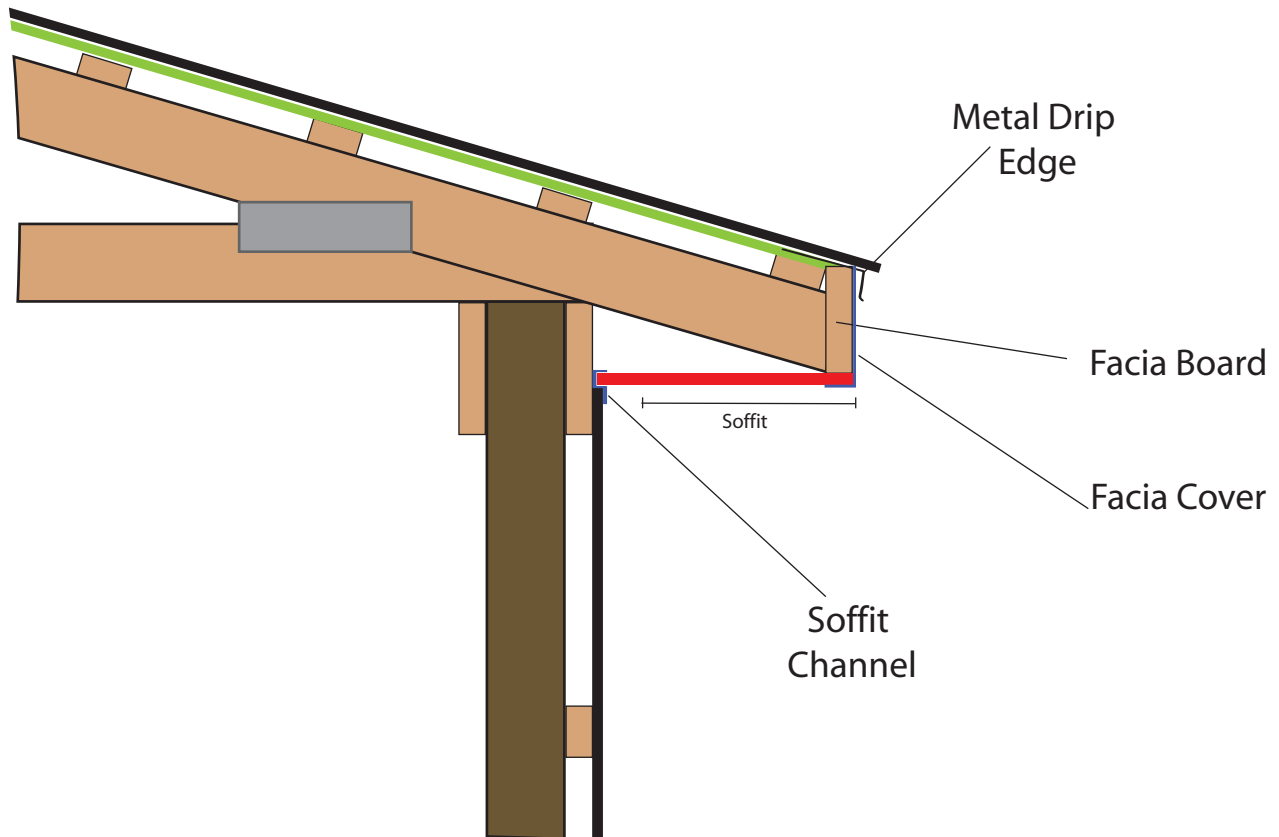
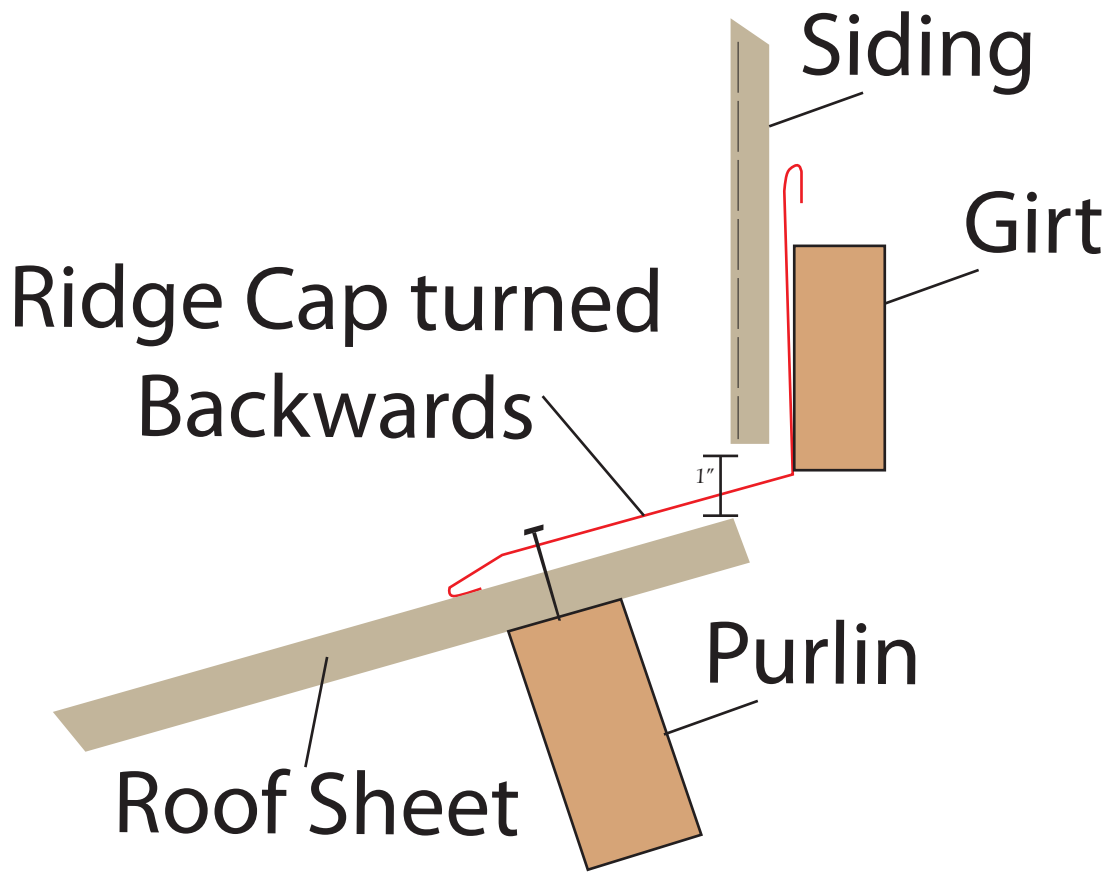

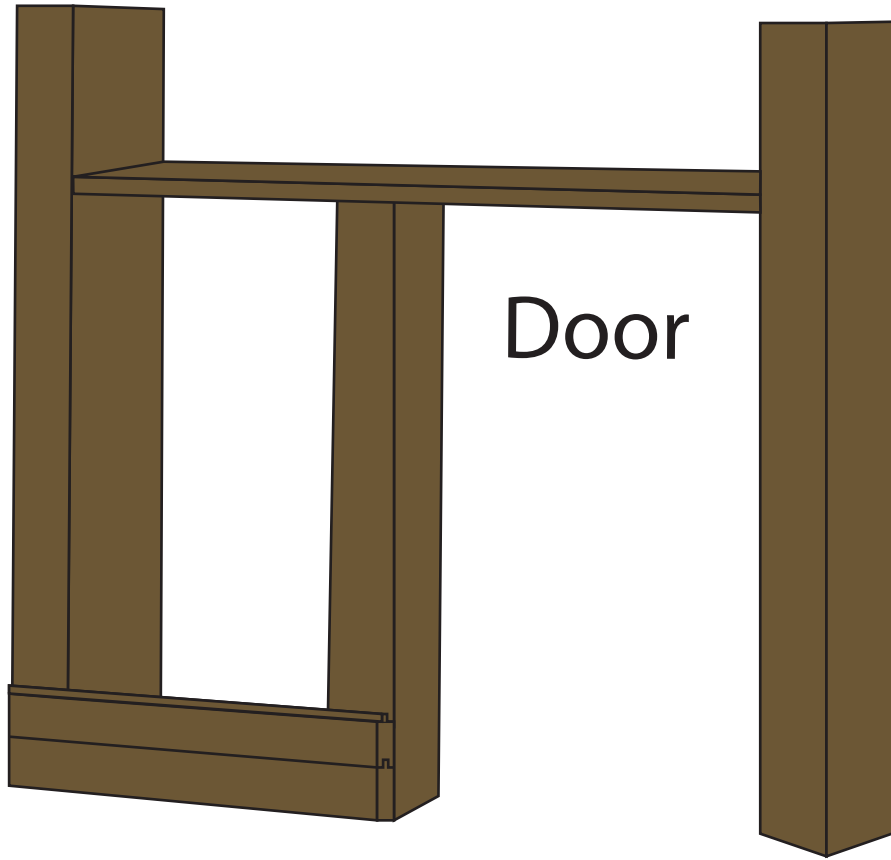

Door

Door Frame (Detail)

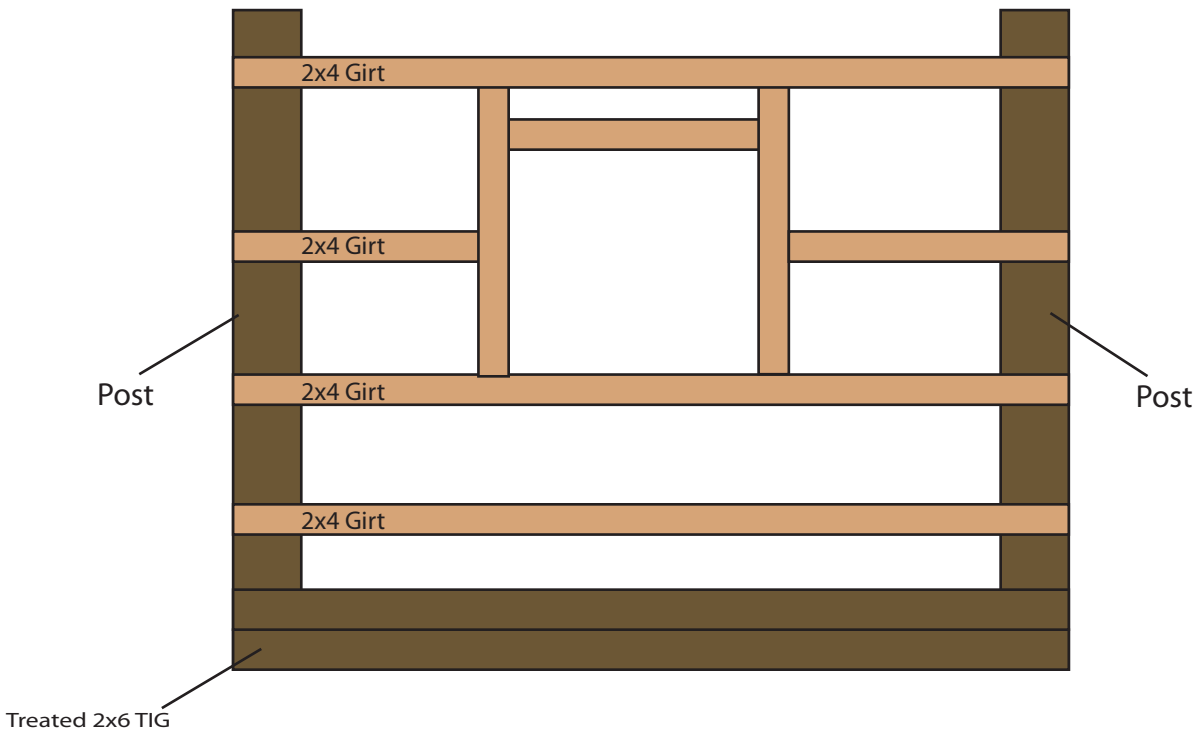

Window Frame (Detail)

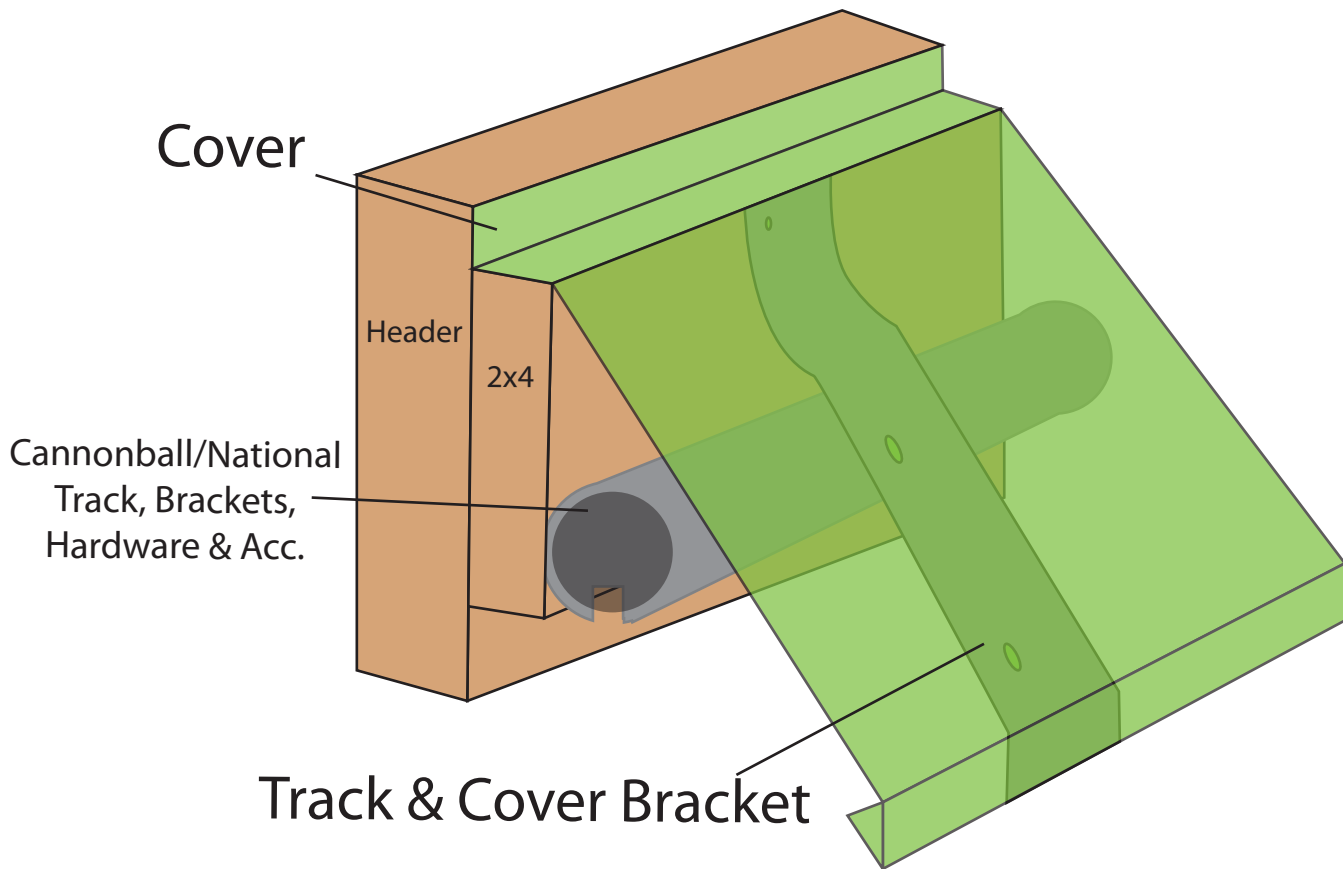
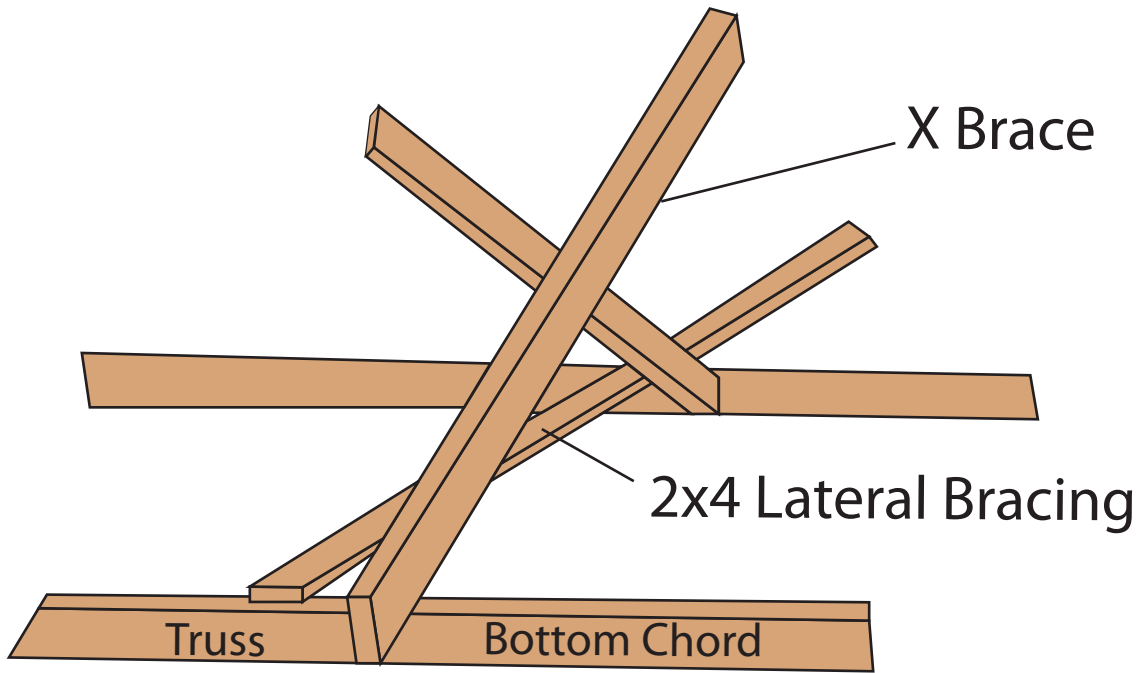

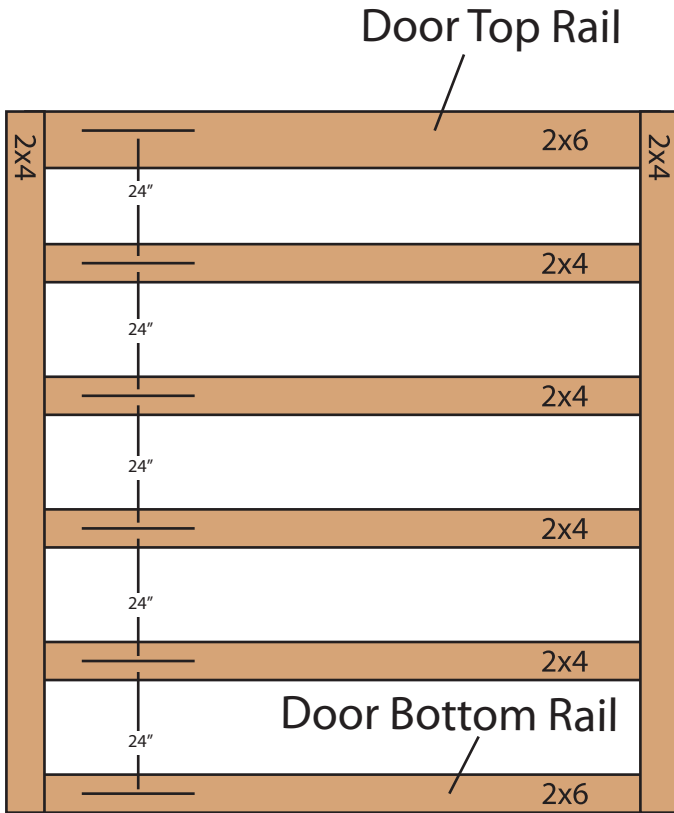

Sliding Door

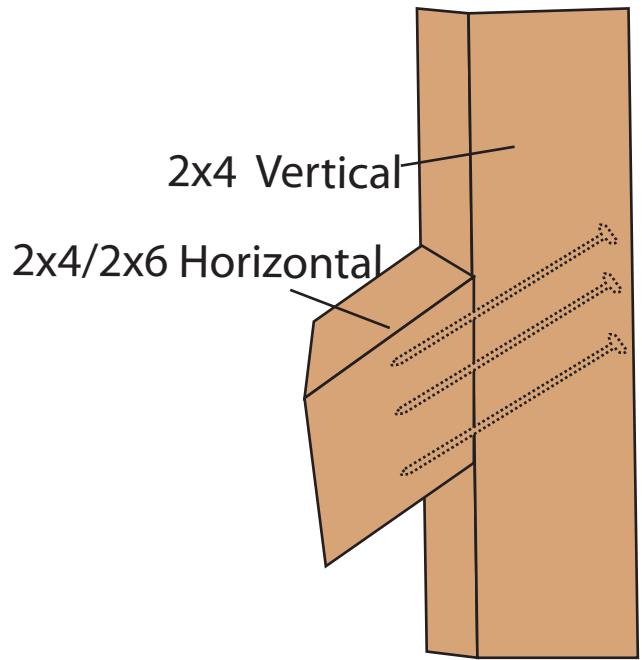

Typical Connection for Sliding Door

Versatile CannonBall® “Key-Hole” Door Track



1

Tap shoulder rivets on mounting brackets into slotted key-holes on the track.

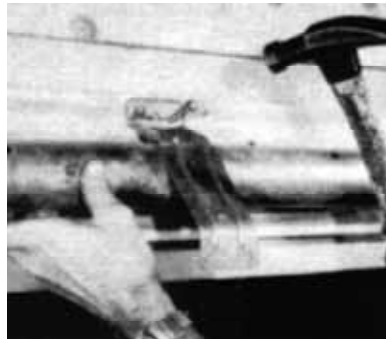

2

Now nail mounting brackets to track plank with ordinary ring-shank nails. No lag-bolts needed.

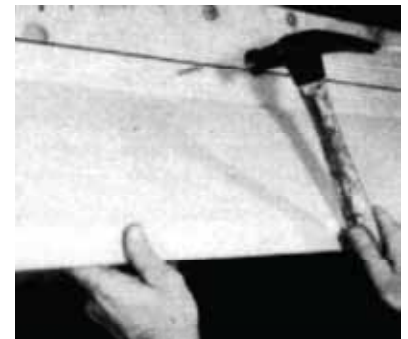

3

Hook bottom lip of track cover onto mounting bracket, nail top in place above track plank.

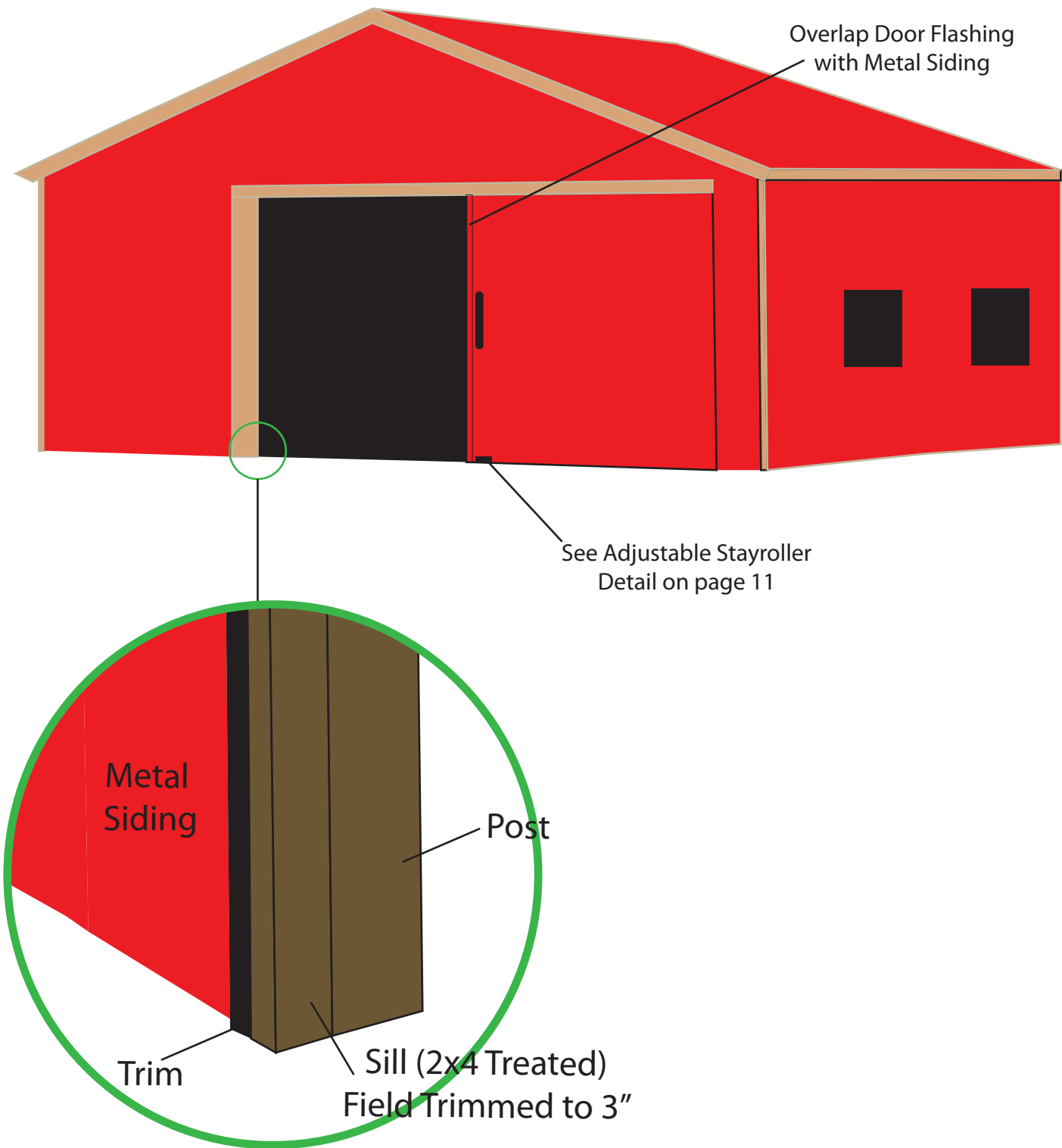

Door Frame Detail

CannonBall® "Bolt-Thru" Trolley Hangers install, adjust easily

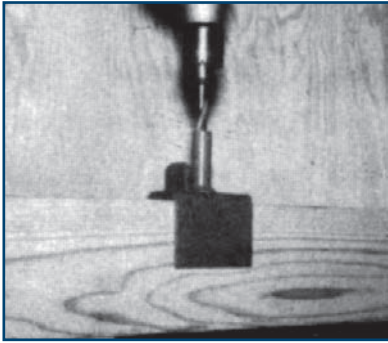

1

Holes are drilled through the top rail of the door frame.

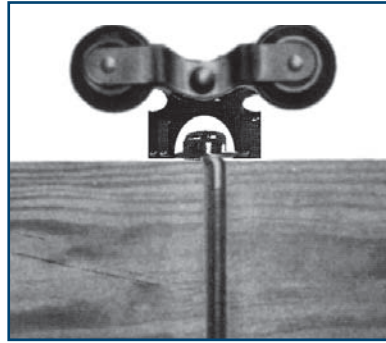

2

Cut-away photo shows how simply the Bolt-Thru Trolley Hanger goes into place after holes are drilled.

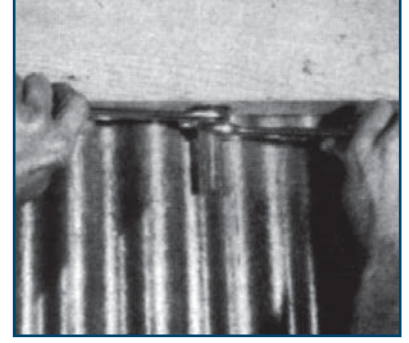

3

Up-down or in-out adjustments after hanging doors are easily made with just a pair of crescent wrenches.

Cam-Latch... simple to install, easy to operate

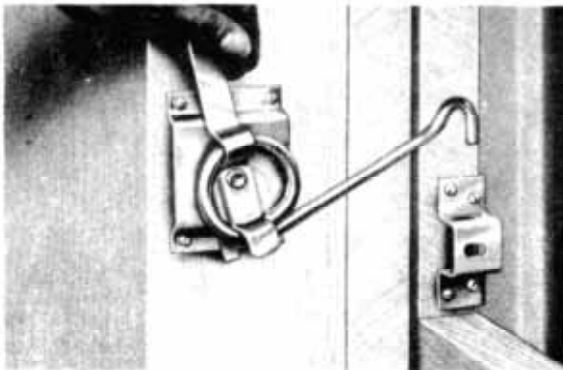

Open

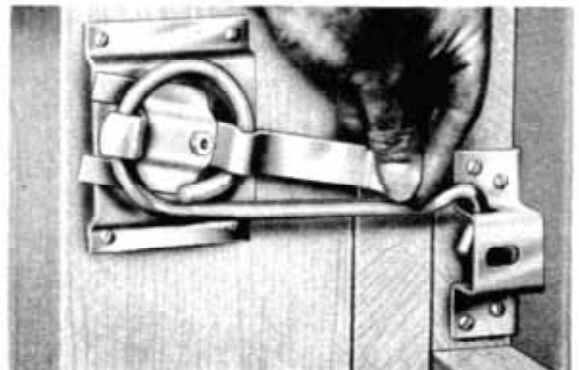

Close

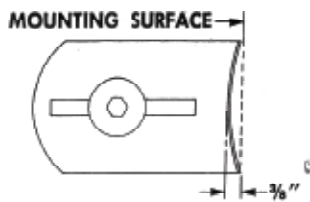

Adjustable Stay Roller

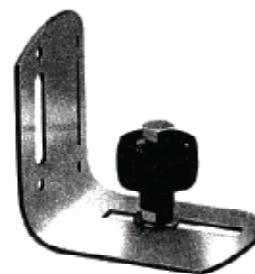
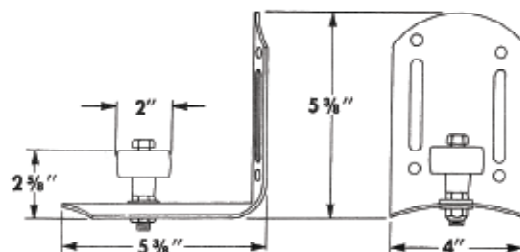

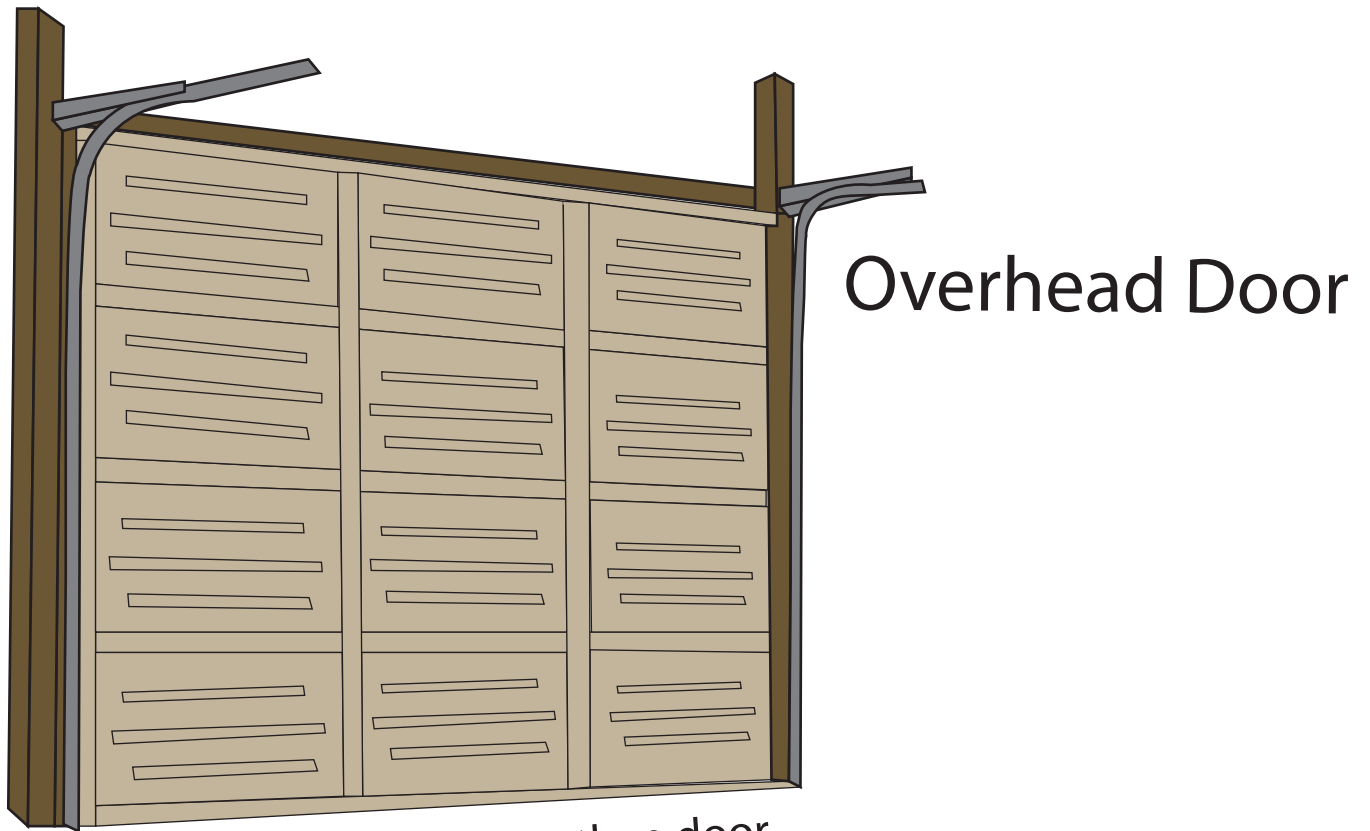
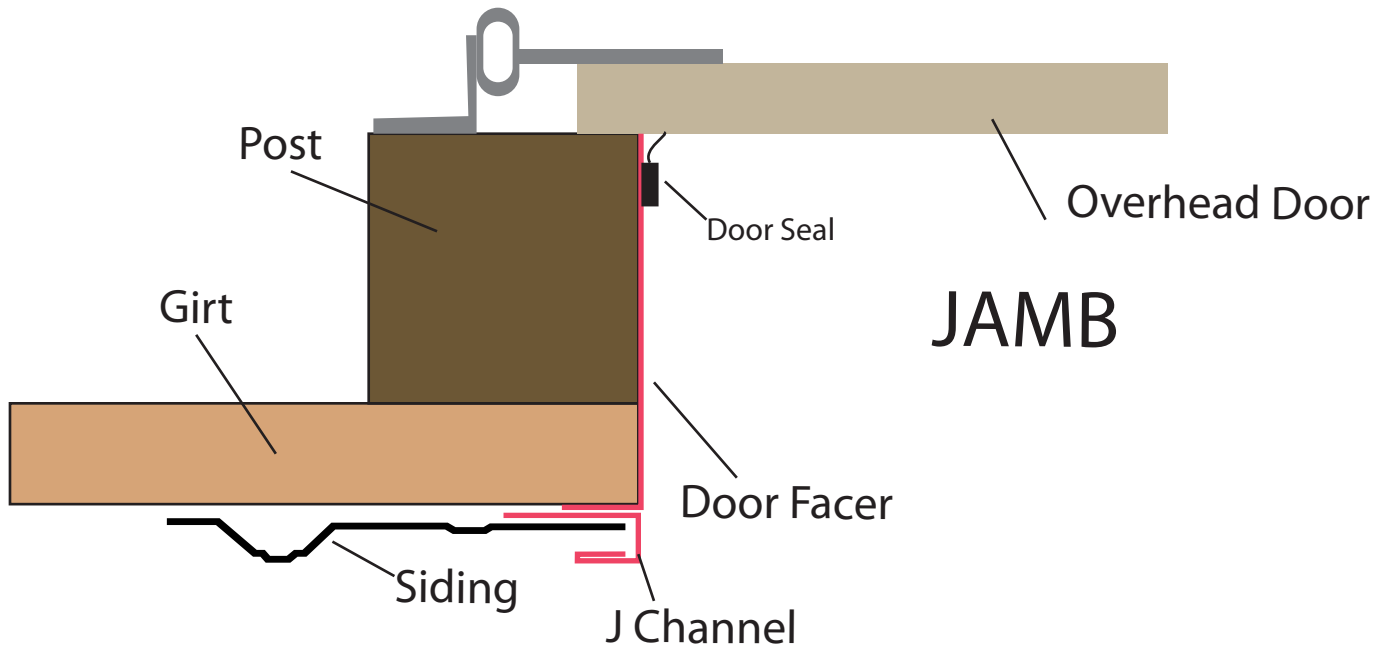

Post to be set in 2" less than door size on width & 1" less on height

